

DRAWING MADE IN AMERICAN PROJECTION

© 1953 BY AMP INCORPORATED. ALL RIGHTS RESERVED. AMP PRODUCTS COVERED BY PATENTS AND/OR PATENTS PENDING.

REVISIONS				
ZONE	LTR	DESCRIPTION	DATE	APPROVED
E		REDRAWN & REVISED PG5563	1-6-70	JM
F		INACTIVATED 2-322128-1 P-7034	6-7-73	JM
G		ADDED 2-322128-2 P-7000	2-12-77	ZAB
H		REV. PER P-8347	4/77	JM
J		OBSOLETE 2-1 PER P.9222	3-1-82	DJM
K		REV G-4680	5-9-88	JT

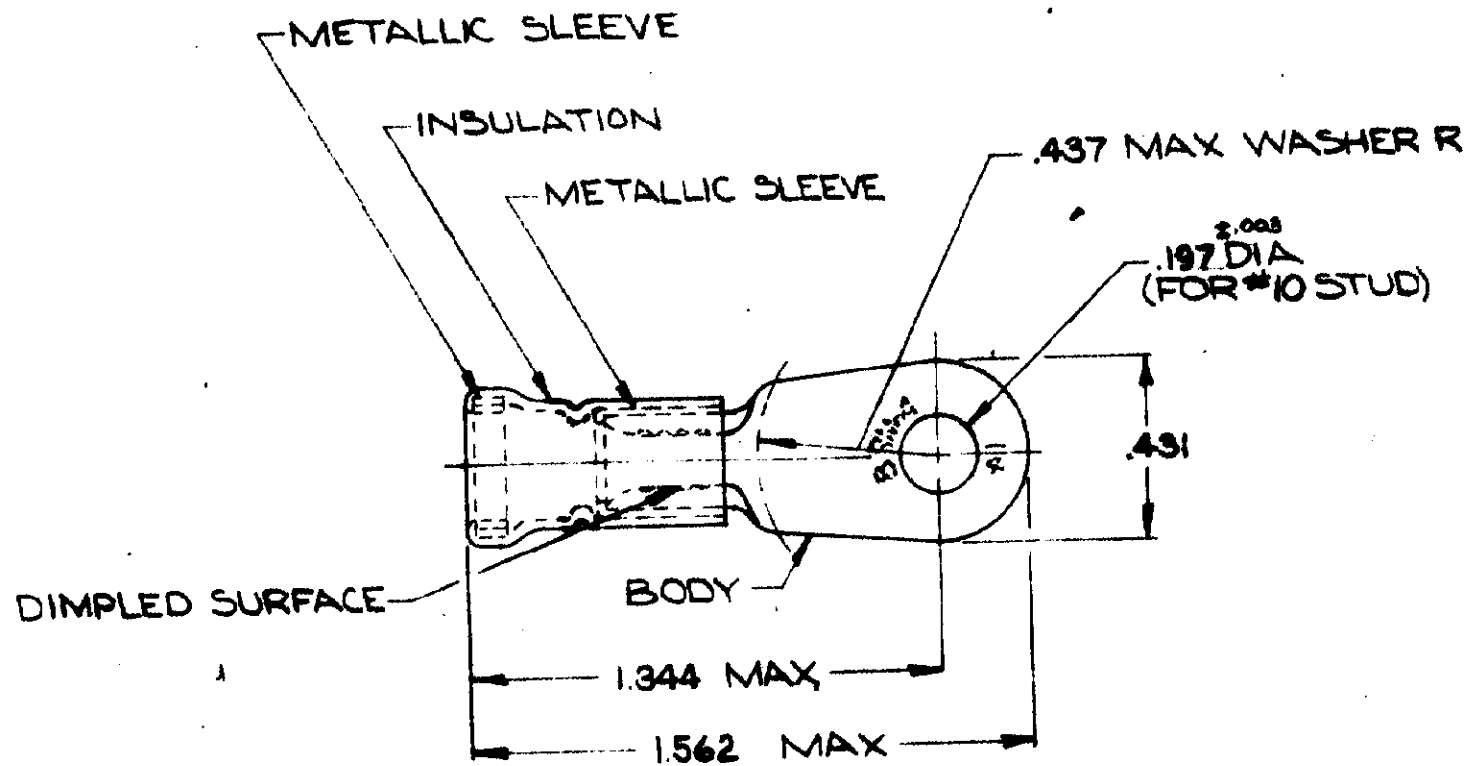

TONGUE MATERIAL THICKNESS = .040 ± .003  
FOR .298 MAX WIRE INS DIA

TABLE I

1	WIRE TERMINAL	SEE TABLE II	BODY: COPPER (QQ-C-576)
			FINISH: (SEE TABLE II)
			INSULATION: PVC COLOR: RED
			METALLIC SLEEVE: COPPER (QQ-C-576)
			METALLIC BAND: STEEL QQ-S-698 (ASTM A109)
			MATERIAL & FINISH
QTY	DESCRIPTION	PART NO.	
UNLESS OTHERWISE SPECIFIED DIMENSIONS ARE IN INCHES TOLERANCES ON: DECIMALS ± .008 ANGLES ± 5°			CONTRACT NO. 11-12-69
MATERIAL			DR. Wayne Mullins
SEE TABLE I.			CHK. M. Encarnacion
			APPD. Swahel 1-7-70
			APPD. M. Encarnacion 1-7-70
			DESIGN APPD.
			OTHER APPD.
		AMP INCORPORATED HARRISBURG, PENNSYLVANIA	
		NAME	WIRE TERMINAL AMPLI-BOND - RING TONGUE WIRE SIZE: 8
SIZE	CODE IDENT NO.	NUMBER	
B	00779	322128	
SCALE	NTS	SHEET	1 OF 1

TABLE II

2-322128-1	GOLD PLATED (MIL-G-45204) TYPE II .00005 MIN. EXT. THK. OVER NICKEL PL. (QQ-N-290) .00003 MIN. EXT. THK.	— OBSOLETE
322128	TIN PLATED (MIL-T-10727)	
PART NO	FINISH	PART NO ON TAPE
		2-322128-2

CUSTOMER DRAWING