

1. Description

The SLVU2.8-4 is a low capacitance TVS (Transient Voltage Suppressor) array designed to protect high speed data interfaces. It has been specifically designed to protect sensitive electronic components which are connected to data and transmission lines from over-stress caused by Electrostatic Discharge (ESD), cable discharge events (CDE), lightning and other induced voltage surges.

2. Features

- IEC 61000-4-2 Level 4 ESD Protection
 - $\pm 30\text{kV}$ Contact Discharge
 - $\pm 30\text{kV}$ Air Discharge
- 450W Peak pulse Power (8/20us)
- Low clamping voltage
- Working voltage: 2.8V
- Low leakage current
- Low capacitance: $C_j = 3\text{pF}$ typ.
- RoHS compliant
- Unidirectional configuration

3. Applications

- 10/100/1000 Ethernet
- WAN/LAN Equipment
- Desktops, Servers, and Notebooks
- Analog Inputs
- Base Station
- Switch Systems

4. Ordering Information

Part Number	Package	Marking	Material	Packing	Quantity per reel	Flammability Rating	Reel Size
SLVU2.8-4	SOP-8	SLVU2.8-4	Halogen free	Tape & Reel	2,500 PCS	UL 94V-0	13 inches

Table-1 Ordering information

5. Pin Configuration and Functions

Pin	Name	Description	Outline	Circuit Diagram
1	IO	Connect to IO		
2	GND	Connect to GND		
3	IO	Connect to IO		
4	GND	Connect to GND		
5	IO	Connect to IO		
6	GND	Connect to GND		
7	IO	Connect to IO		
8	GND	Connect to GND		

Table-2 Pin configuration

6. Specification

6.1. Absolute Maximum rating

Over operating free-air temperature range (unless otherwise noted)

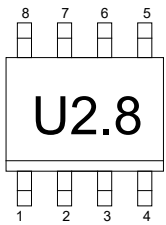
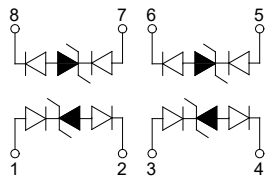
Parameters	Symbol	Min.	Max.	Unit
Peak pulse power (tp=8/20us)@25°C	P _{pk}	-	450	W
Peak pulse current (tp=8/20us)@25°C	I _{PP}		20	A
ESD (IEC61000-4-2 air discharge) @25°C	V _{ESD}	-	±30	kV
ESD (IEC61000-4-2 contact discharge) @25°C	V _{ESD}	-	±30	kV
Junction temperature	T _J	-	125	°C
Operating temperature	T _{OP}	-40	85	°C
Storage temperature	T _{STG}	-55	150	°C
Lead temperature	T _L	-	260	°C

Table-3 Absolute Maximum rating

6.2. Electrical Characteristics

At TA = 25°C unless otherwise noted

Parameter	Symbol	Conditions	Min.	Typ.	Max.	Units
Reverse Stand-off Voltage	V_{RWM}				2.8	V
Reverse Breakdown Voltage	V_{BR}	$I_T=1mA$	3			V
Reverse Leakage Current	I_R	$V_{RWM}=2.8V$			0.1	μA
Clamping Voltage	V_C	$I_{PP}=1A$; $t_p=8/20\mu s$		5		V
Clamping Voltage	V_C	$I_{PP}=20A$; $t_p=8/20\mu s$		25		V
Junction Capacitance	C_J	$V_R=0V$; $f=1MHz$		3		pF

Table-4 Electrical Characteristics

Symbol	Parameters
V_{RWM}	Peak Reverse Working Voltage
I_R	Reverse Leakage Current @ V_{RWM}
V_{BR}	Breakdown Voltage @ I_T
I_T	Test Current
I_{PP}	Maximum Reverse Peak Pulse Current
V_C	Clamping Voltage @ I_{PP}
I_F	Forward Current
V_F	Forward Voltage @ I_F

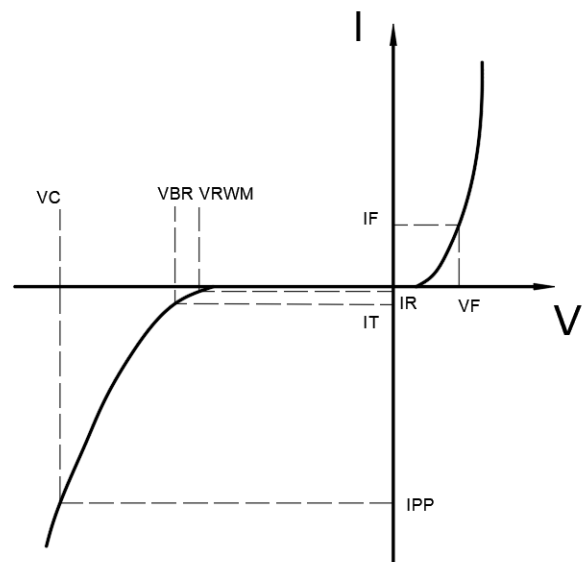

7. Typical Characteristic

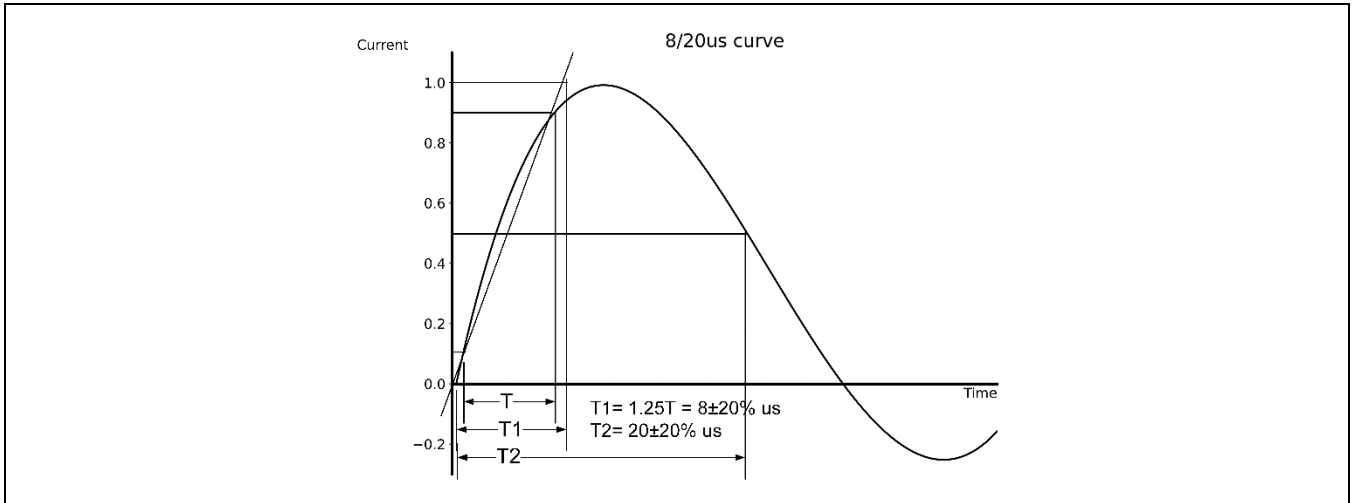

8. Typical Application

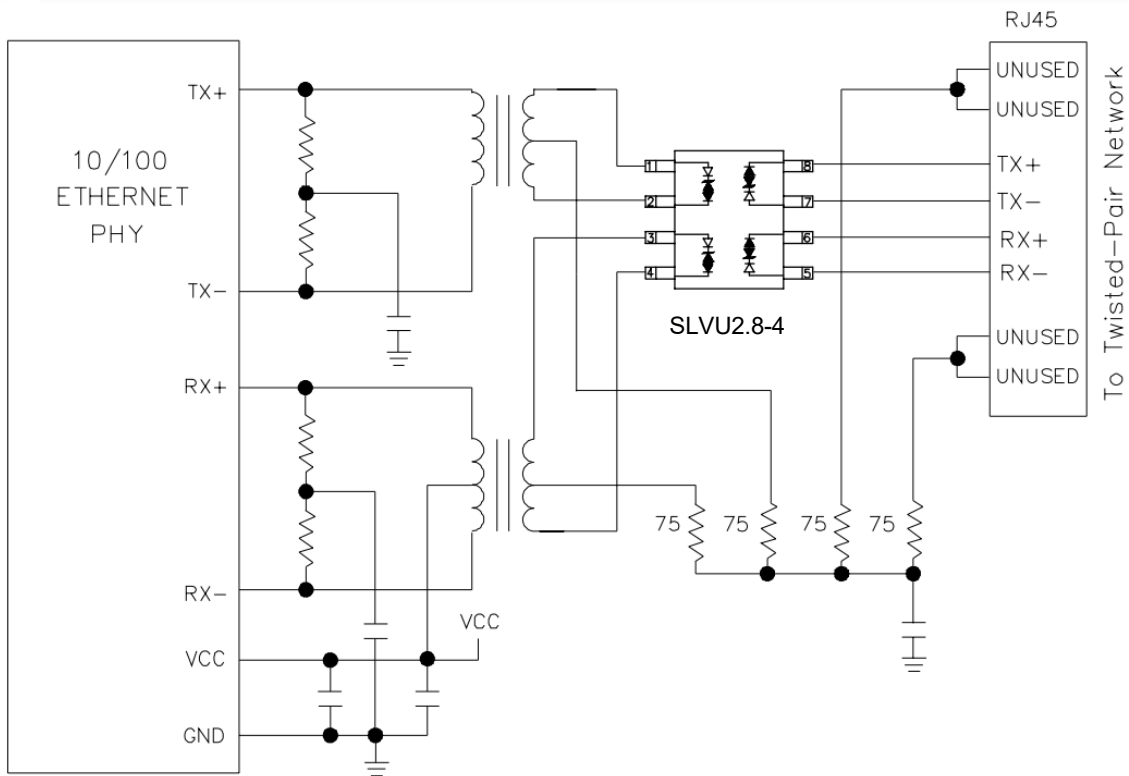

Typical Interface Application

9. Dimension

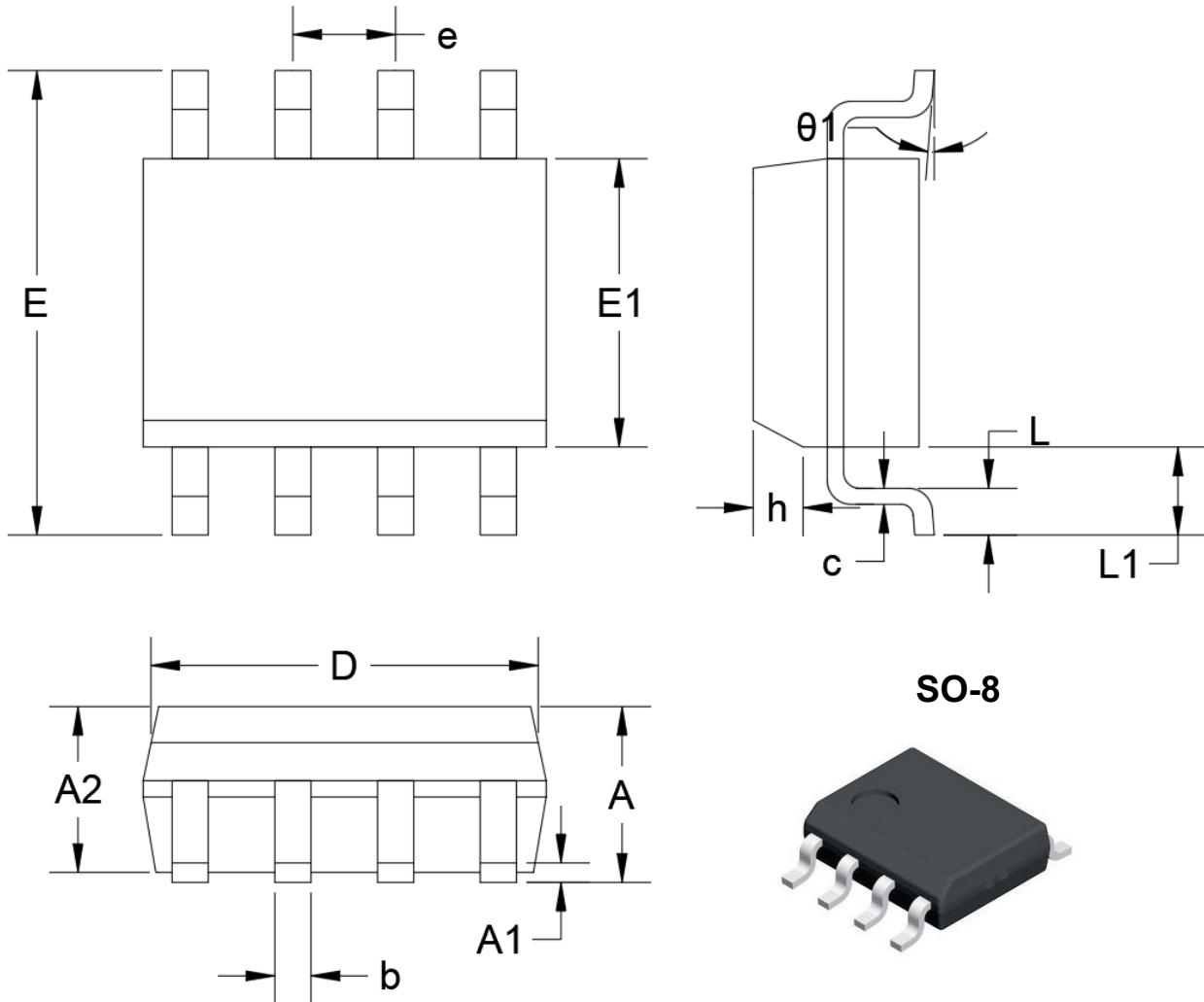

Dimensions in Millimeters					
Symbol	Min.	Max.	Symbol	Min.	Max.
A	1.35	1.75	e	1.27 BSC	
A1	0.10	0.25	h	0.25	0.50
A2	1.25	1.65	L	0.40	1.04
b	0.31	0.51	L1	1.04	
c	0.17	0.25	θ 1	0°	8°
D	4.80	5.00			
E1	3.80	4.00			
E	6.00 BSC				

Table-5 Product dimensions

10. Recommended Land Pattern

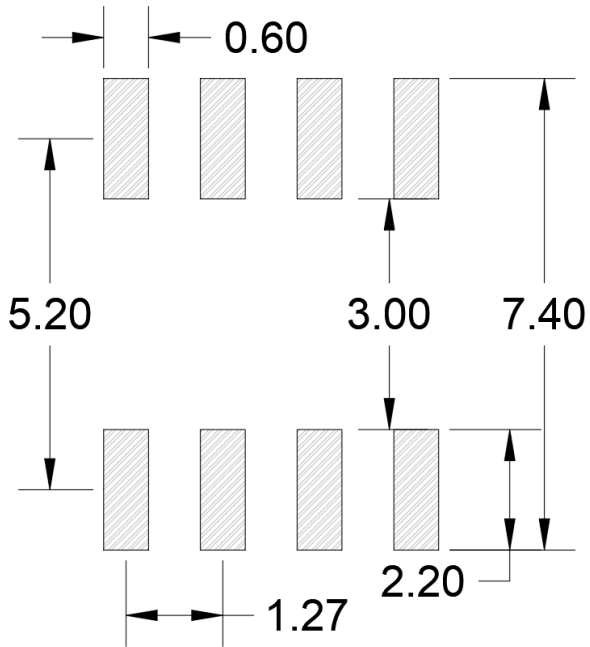

Note:

1. Controlling dimension: in millimeters
2. General tolerance: $\pm 0.05\text{mm}$
3. The pad layout is for reference only